

AUTOMATIC TYING STATION (ATS)

A MOVING EXPERIENCE. The ATS 2000 Automatic Tying Station can help you efficiently move bundles through the tying process. Felins' new modular ATS 2000 Tying Station combines an enhanced model 2000 Series Tyer integrated with two sections of split slider conveyors. Together, these modules provide the excellence and reliability you've come to expect from Felins.



HIGHER PRODUCTIVITY AND LOWER COSTS are just two of the benefits you'll discover with the ATS 2000 Tying Station. Besides offering speed unequalled by hand tying, the ATS 2000 enables you to reduce labor costs by eliminating unnecessary handling.

BUILT TO YOUR SPECIFICATIONS, Felins' ATS 2000 Tying Station will meet your needs exactly in both size and speed. Depending on your application requirements, we can alter the length of the entry and exit conveyors on each side of the tyer. These integrated conveyor sections are controlled by state-of-the-art time delay sequencing electronics.

WE WORK CLOSELY WITH YOU to effectively fit the ATS 2000 Automatic Tying Station into your existing facility. Whether you currently utilize conveyors or not, the ATS 2000 can help you improve productivity while lowering costs.

For more information and pricing, contact Felins Incorporated at

1-800-336-3220

8304 W. Parkland Court • Milwaukee, Wisconsin, 53223 • Tel. 414-355-7747 • Fax 414-355-7559

Internet www.felins.com • E-Mail salesteam@felins.com

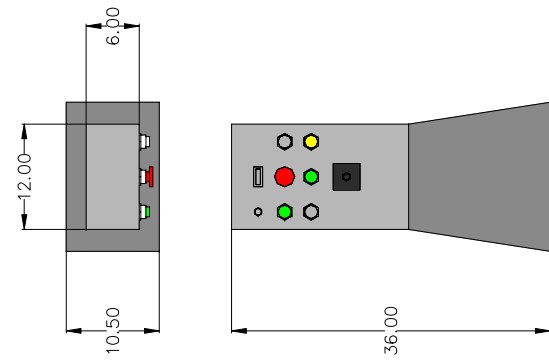

PORTABLE CONTROL PANEL

FELINS
ATS TURBO 2000

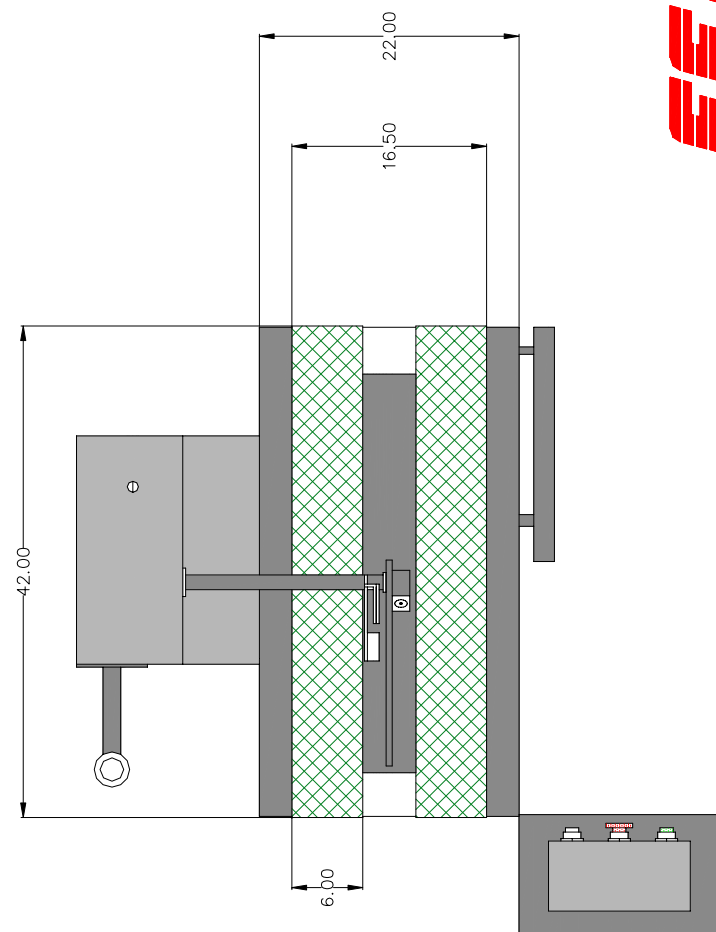
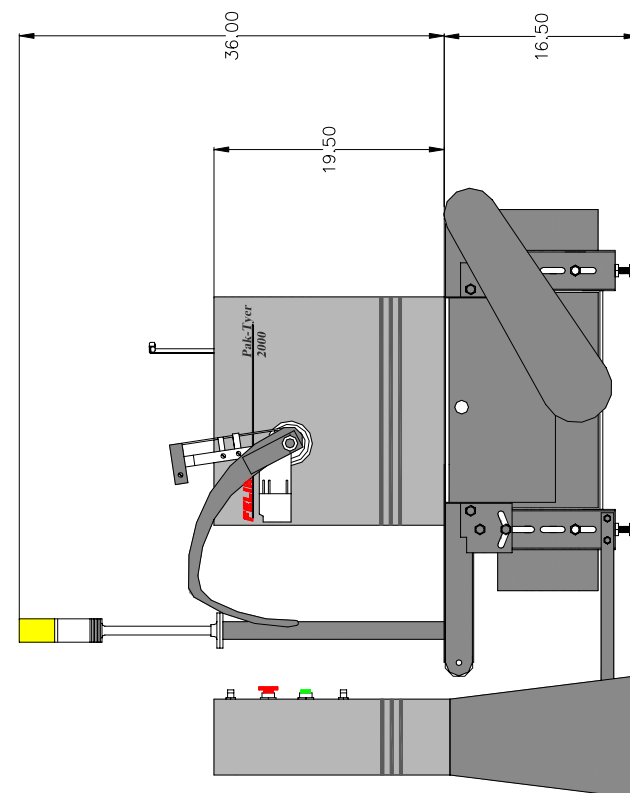
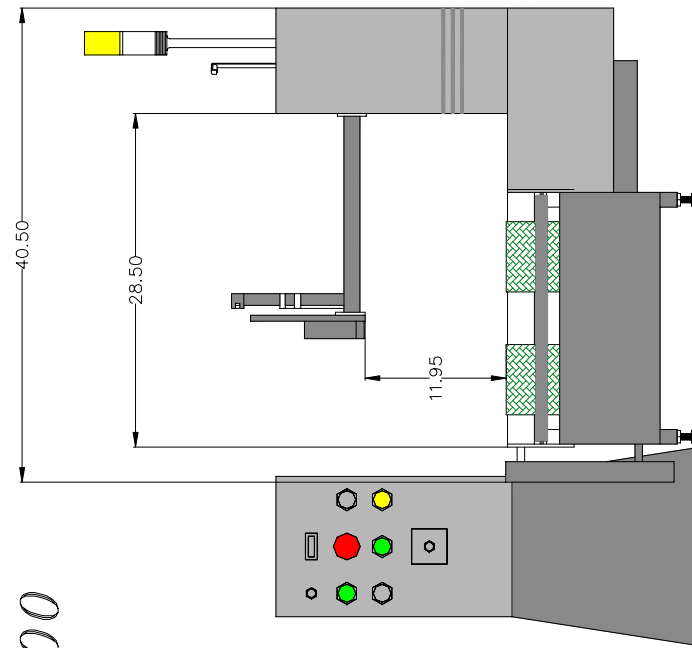

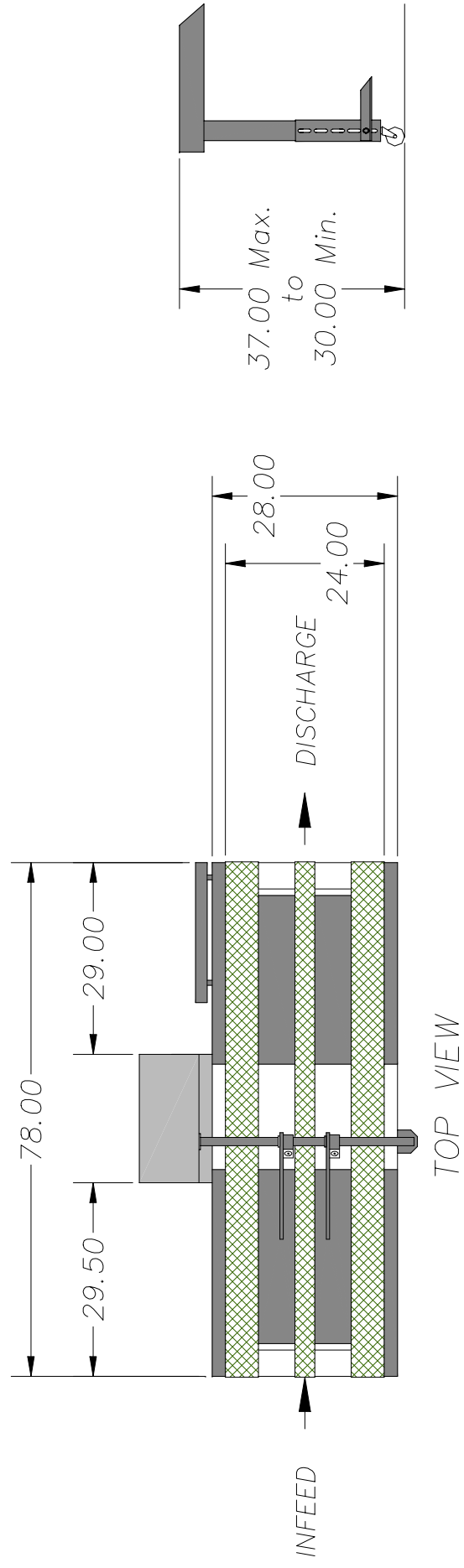

HEIGHT ADJUSTMENT

FELINS
ATS 2000-12 TANDEM

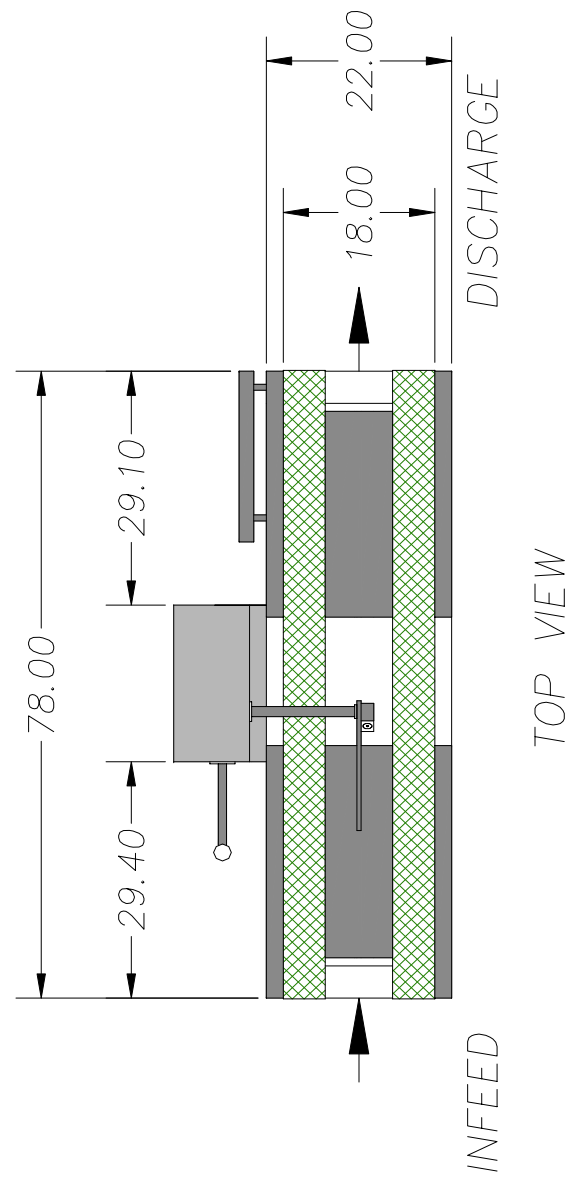
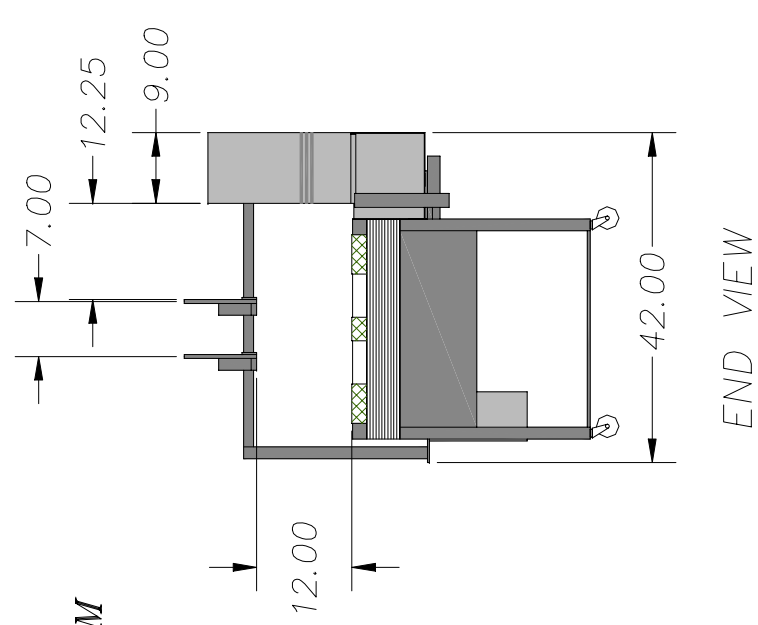
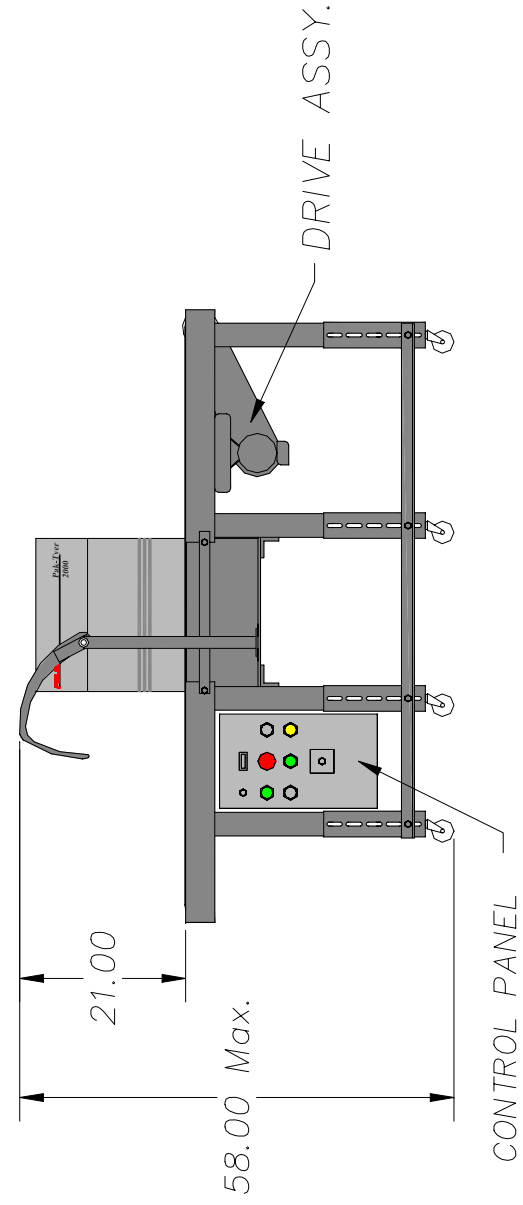

HEIGHT ADJUSTMENT

FELINS
ATS 2000-12

