

## **MEAT/POULTRY TYER**

**INTRODUCING THE FELINS MEAT/POULTRY TYER 2000.** This commercial food processing tyer is designed for use in the meat processing environment. Stainless steel, chrome plating and a water tight electrical system make this versatile tyer wash down ready.



**SPECIAL FEATURES** include PLC drive control, direct drive power train, variable cycle speed control, hands free knee activation switch, fold down front and side panels for quick and easy wash down, heads up control panel for easy access, adjustable string tension control, quick change cone dispenser, stand with 4 independent swivel casters - 2 locking -for portability, plus many other operator friendly features.

**COMPACT AND PORTABLE.** This table top unit is perfect for even the smallest work areas. It is also available with a cart for mobility and adjustable height leg supports. The six inch (15 cm) height clearance gives this meat and poultry tyer the capability to tie large items in one second.

**VERSATILITY.** This low cost tyer uses a wide variety of food grade cotton twines, elastics, elastomers and even consumable tying materials. At 25 cycles per minute, the Felins Meat/Poultry tyer will increase your productivity while reducing your overall bundling costs.

*For more information and pricing, contact Felins Incorporated at*

**1-800-336-3220**

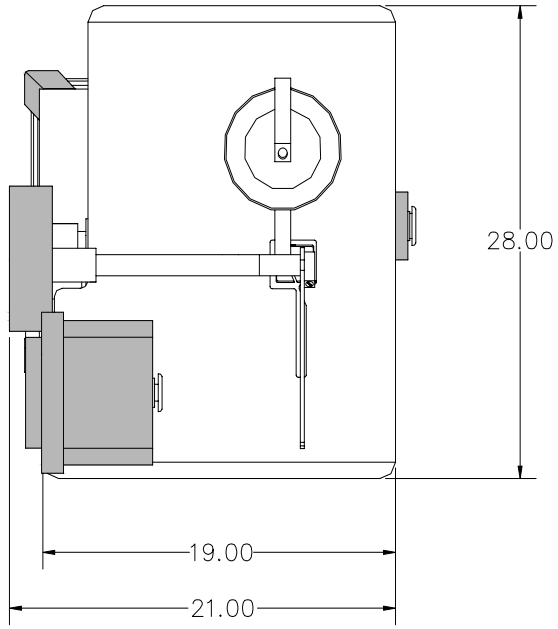

# ***FELINS***

## **MEAT/POULTRY TYER**

