



LAUNDRY BUNDLE MANAGEMENT

Banding, tying and shrink wrapping solutions for the laundry industry





TABLE OF CONTENTS

We know the commercial and industrial laundry industry relies on consistent, cost-effective processes that result in presentable products – every time.

Whether you've been struggling to eliminate your backlog, can't find and retain labor, or need to bundle several product types and sizes at one location, we have solutions that can help ease your pains! From stand-alone to semi-automatic or fully-automated, our systems have been designed specifically for optimizing productivity and more efficiently allocating resources for laundry bundling.

STAND ALONE MACHINES	4
US-2000 TTP	4
PAK-TYER™	5
ROTARY PAK-TYER™	6
TYING MACHINE OPTIONS	7
AUTOMATION SYSTEMS	8
BANDING	9
US-2000 TRW-FD-MP-R	
TYING	10
TURBO-TYER	
ALTS	
SHRINK WRAPPING	14
TP-100	
TPS	
TP-200 & TP-300	
AUTOMATION SYSTEM OPTIONS	20



STAND ALONE MACHINES

US-2000 TTP

Tracking products through the cleaning and delivery process is becoming continually more important.

With the introduction of banding into your facility, you can now print variable data directly onto a band to identify each bundle and securely hold them together for delivery.



MACHINE DIMENSIONS:	Width: 52" Height: up to 66" Depth: 22"
POWER REQUIREMENTS:	110V
AIR REQUIREMENTS	90 psi
SPEED:	Up to 30 bands/minute
MAX. PRODUCT SIZE	15"W x 9.8"H x 17.7"L



STAND ALONE MACHINES

PAK-TYER

Tired of troublesome strapping machines? Is hand tying slowing down your operations?

Replace unfilled positions and optimize your operations with the Pak-Tyer™, a semi-automatic tying machine.

Perfect for any sized facility, the Pak-Tyer is an efficient alternative to manual tying with a small footprint capable of completing up to 2,400 cycles per hour (that's 40 per minute!).



MODEL:	2000-6	2000-8	2000-10	2000-12	2000-16	2000-22
MACHINE DIMENSIONS:	Width: 29" Height: 58" Depth: 25"	Width: 28" Height: 60.5" Depth: 31"	Width: 35" Height: 63" Depth: 37"	Width: 35" Height: 68" Depth: 37"	Width: 42" Height: 72" Depth: 36.5"	Width: 48" Height: 78" Depth: 36"
MACHINE WEIGHT:	235 lbs	260 lbs	260 lbs	290 lbs	325 lbs	360 lbs
TABLE SIZE (W x D):	28" x 16"	28" x 16"	35" x 24"	35" x 24"	42" x 24"	42" x 24"
POWER REQUIREMENTS:	115V, 220V					
SPEED:	Up to 40 cycles/minute					
PRODUCT HEIGHT:	6" max.	8" max.	10" max.	12" max.	16" max.	22" max.
PRODUCT DIAMETER:	1" minimum					



STAND ALONE MACHINES

ROTARY PAK-TYER

Tying shouldn't be a hassle, even when your products require strong tension. The Rotary Pak-Tyer™ (RPT) helps optimize your operations by doing the tying for you and keeping your products firmly bundled with single, double and even cross-ties.



MODEL:	RPT-8	RPT-10	RPT-12	RPT-16	BMT-36
MACHINE DIMS (W x H x D):	25" x 47.5" x 30"	27" x 52" x 32"	30" x 54" x 32"	37.5" x 61.5" x 32"	60" x 65" x 49"
MACHINE WEIGHT:	238 lbs	250 lbs	260 lbs	330 lbs	425 lbs
THROAT DEPTH:	9.75"	9.75"	9.75"	9.75"	14"
MAX. PRODUCT OPENING (W x H):	11.25" x 10"	14.5" x 14.5"	18" x 17.75"	24.5" x 23.25"	39" x 35"
POWER REQUIREMENTS:	115V				
SPEED (CYCLES/MIN):	Up to 48	Up to 45	Up to 45	Up to 44	Up to 36



TYING MACHINE OPTIONS

Improved productivity and safety are vital to efficient, effective production. That's why we offer several additional machine options - so you can maximize the effectiveness of your Felins solution to better optimize your overall operations.

TANDEM ARMS

Double your efficiency with a second tying arm. Ideal for larger products, tandem arms will simultaneously make two individual ties on each bundle, preventing you from needing to feed products twice.

Depending on your product size or bundling requirements, the tandem arms can be spaced 6.5 to 8 inches apart on your Pak-Tyer.



VACUUM TAIL REMOVAL (VTR)

Daily cleanup? Let the Vacuum Tail Removal (VTR) system do it for you.

This option automatically removes cut-offs and keeps your tying area clean. That means not only will your facility be cleaner, you'll need less frequent machine maintenance and your tying area will be safer for operators.

OBSTRUCTION SENSORS

For facilities where throughput is extremely high, preventing an accidental machine cycle is imperative.

By enhancing your machine with electronic photo obstruction sensors, you'll reduce unintentional machine cycling, preventing product damage and machine jams.

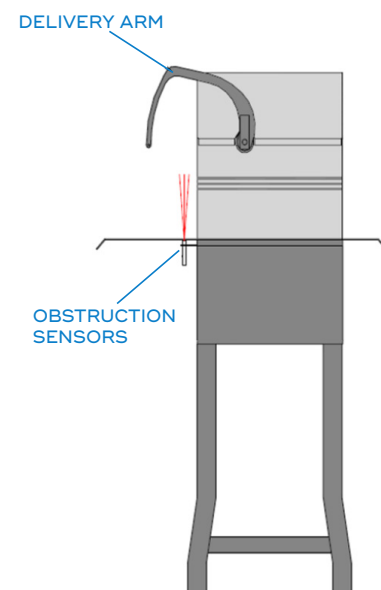

ACTIVATION METHODS

Whether you want extra control over your products or to achieve higher throughput, your Felins tying machine can be equipped with an activation method that's best for your production.

A foot trip can be placed on the floor next to your machine for easy operator access or, for even faster operation, product sensors can be added for automatic activation of your Pak-Tyer.



AUTOMATION SYSTEMS

Facilities with high throughput require robust automation. Each of our automation systems can be customized for your facility and operational goals.

So, whether you're enhancing your tracking capabilities, tying towels or shrink wrapping high-end linens (or both!), we can develop a custom solution that can help you become more efficient and sustainable than ever before.

BANDING SYSTEMS	9
US-2000 TRW-FD-MP-R	9
TYING SYSTEMS	10
TURBO-TYER	10
ALTS	12
SHRINK WRAPPING SYSTEMS	14
TP-100	14
TPS	16
TP-200 & TP-300	17



AUTOMATION SYSTEMS



US-2000 TRW-FD-MP-R

After products are cleaned and stacked, making sure they get to their intended destinations and tracking the progress along the way can be challenging.

Whether you're kitting uniforms or simply want to be sure the proper linens get to the correct customer, a banding solution can help you bundle and label in one easy step without using adhesives.

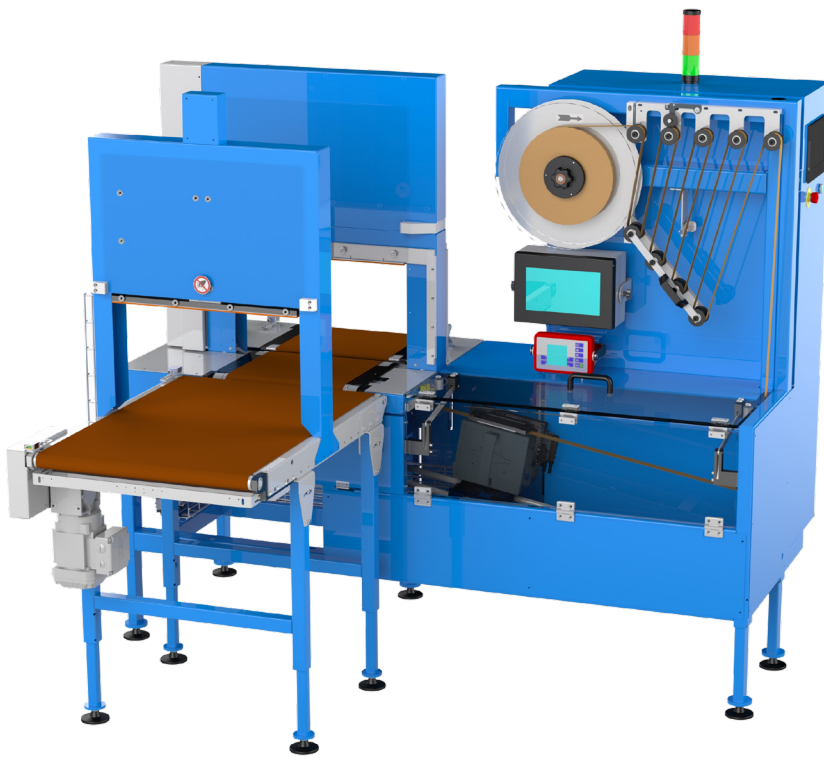

MACHINE DIMENSIONS:	64.2"W x 66.7"H x 62.2"D
MAX. BUNDLE SIZE:	15"W x 9.8"H x 17.7"L
POWER REQUIREMENTS:	230V
AIR REQUIREMENTS:	90 psi, clean-dry air
SPEED:	Up to 20 bands/minute



AUTOMATION SYSTEMS

TURBO-TYER

Placed after a small-piece folder or hand folding line, the Turbo gives you the best of both worlds - an automated machine with a small footprint. You don't need to worry about clunky machines that require constant attention. The Turbo is designed to reduce operating costs with minimal maintenance.

Even better? Equipped with our economical twine or polytape, the Turbo can tie up to 720 bundles per hour. Talk about efficiency!



MACHINE DIMENSIONS:	37"W x 74"H x 60"D
MAX. BUNDLE SIZE:	24"W x 12"H
POWER REQUIREMENTS:	115V
AIR REQUIREMENTS:	80 psi / 1 cfm, clean-dry air
SPEED:	Up to 12 cycles/minute



AUTOMATION SYSTEMS

TURBO-TYER - SAMPLE TYING SYSTEM LAYOUT

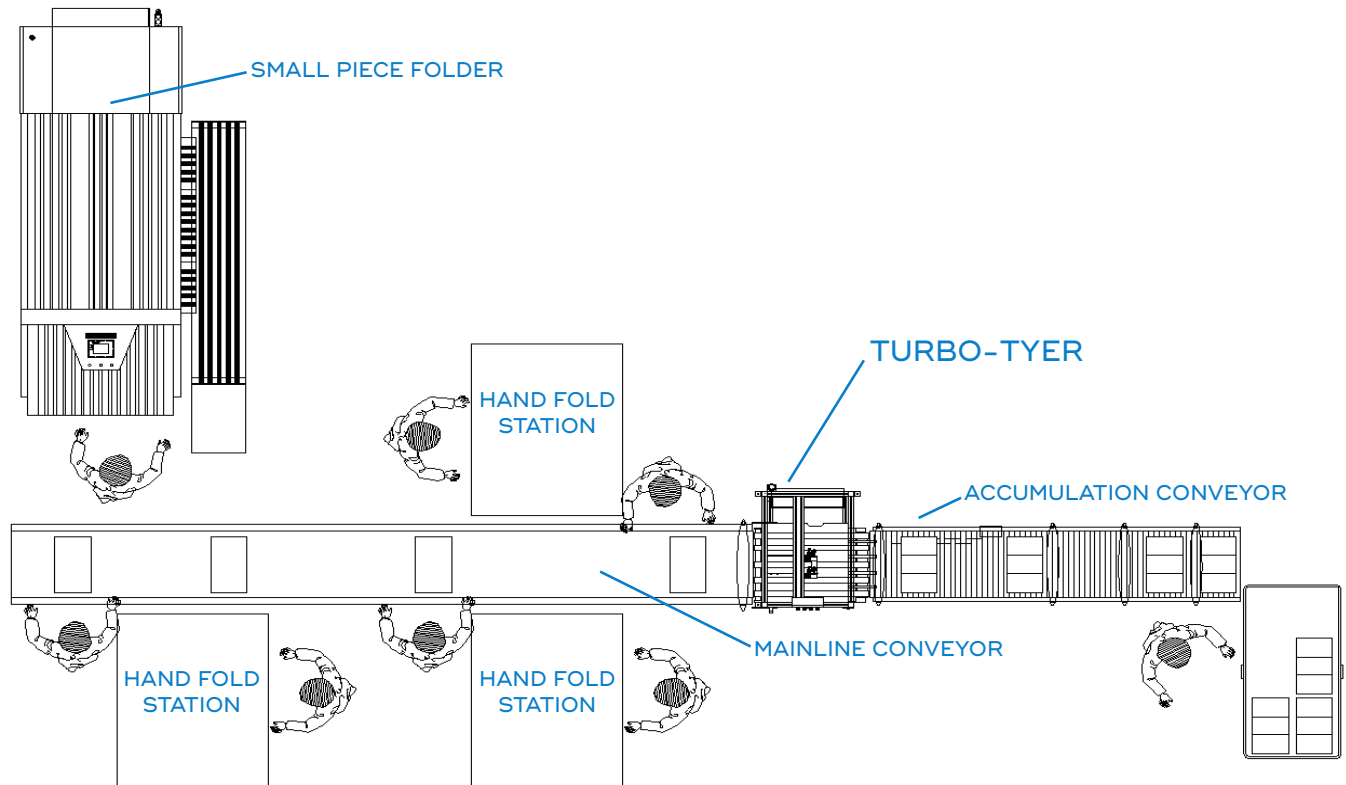



AUTOMATION SYSTEMS

AUTOMATED LAUNDRY TYING SYSTEM (ALTS)

The ALTS is the most robust laundry tying machine on the planet. When installed with Felins laundry conveyance, this system is capable of automatically tying up to 720 bundles per hour while significantly reducing operating costs.

What does that mean for you? It means you can focus on your operations and not worry about your pack out area.



MODEL:	ALTS 300/420
MACHINE DIMENSIONS:	91"W x 75"H x 55"D
MAX. BUNDLE HEIGHT:	12"H / 16"H (300 / 420)
POWER REQUIREMENTS:	115V
AIR REQUIREMENTS:	100 psi / 5 cfm, clean-dry air
SPEED:	Up to 12 cycles per minute



AUTOMATION SYSTEMS

AUTOMATED LAUNDRY TYING SYSTEM (ALTS) - SAMPLE LAYOUT

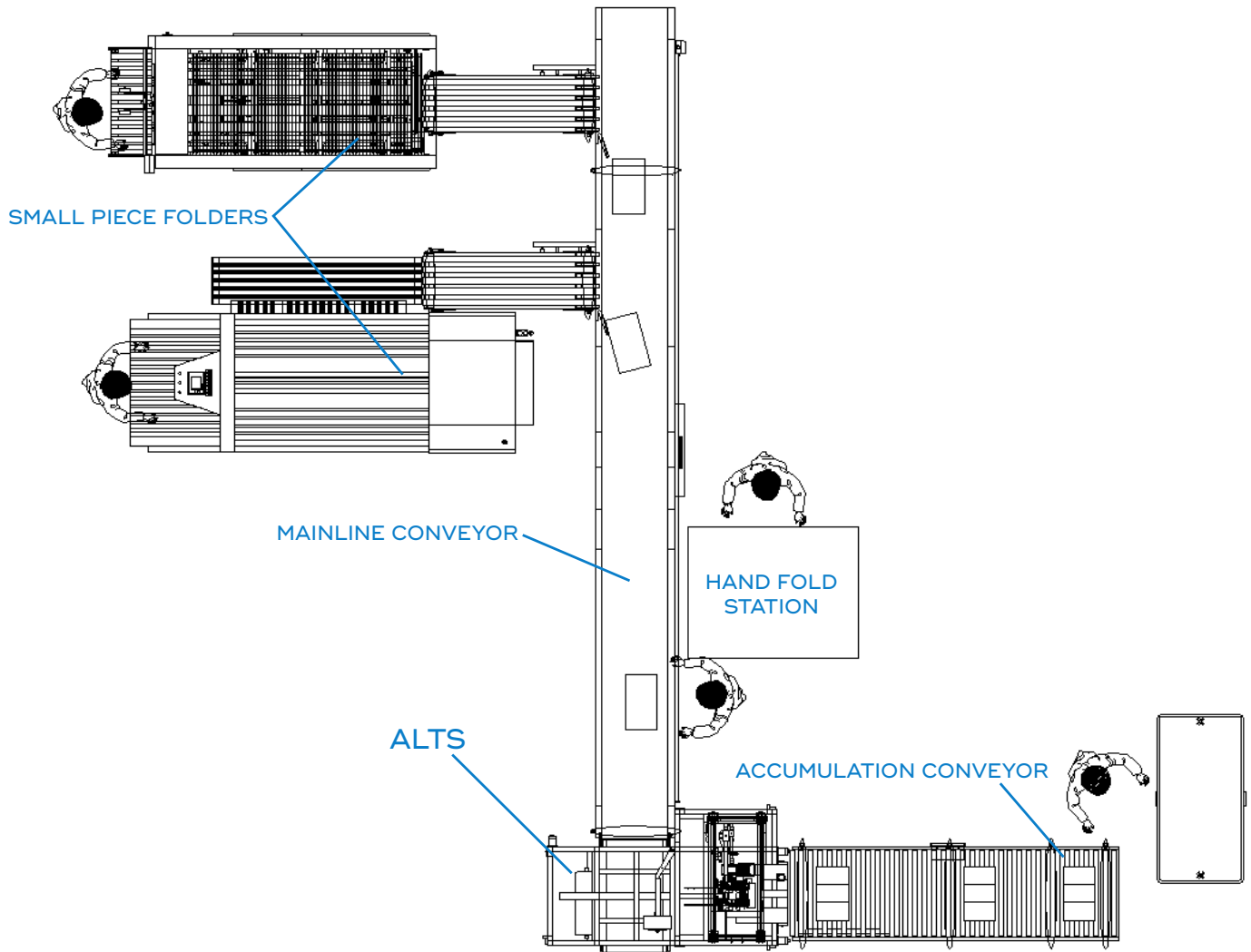

AUTOMATION SYSTEMS



TP-100

With a small footprint, the TP-100 is designed for facilities that want to eliminate hand wrapping but don't have volume for a fully-automated solution.

Combined with a fully controllable heat tunnel and adjustable conveyors, the TP-100 can wrap as fast as 2 or 3 hand wrappers, making improving your PPOH easier than ever.



MODEL:	TP-100 Wrapper	2215-4 Heat Tunnel
MACHINE DIMENSIONS:	47"W x 55"H x 85"L	51"W x 70.5"H x 72"L
MAX. BUNDLE SIZE:	23"W x 11"H x 30"L	
POWER REQUIREMENTS:	220V	
SPEED:	Up to 12 pcs/minute	



AUTOMATION SYSTEMS

TP-100 - SAMPLE WRAPPING SYSTEM LAYOUT

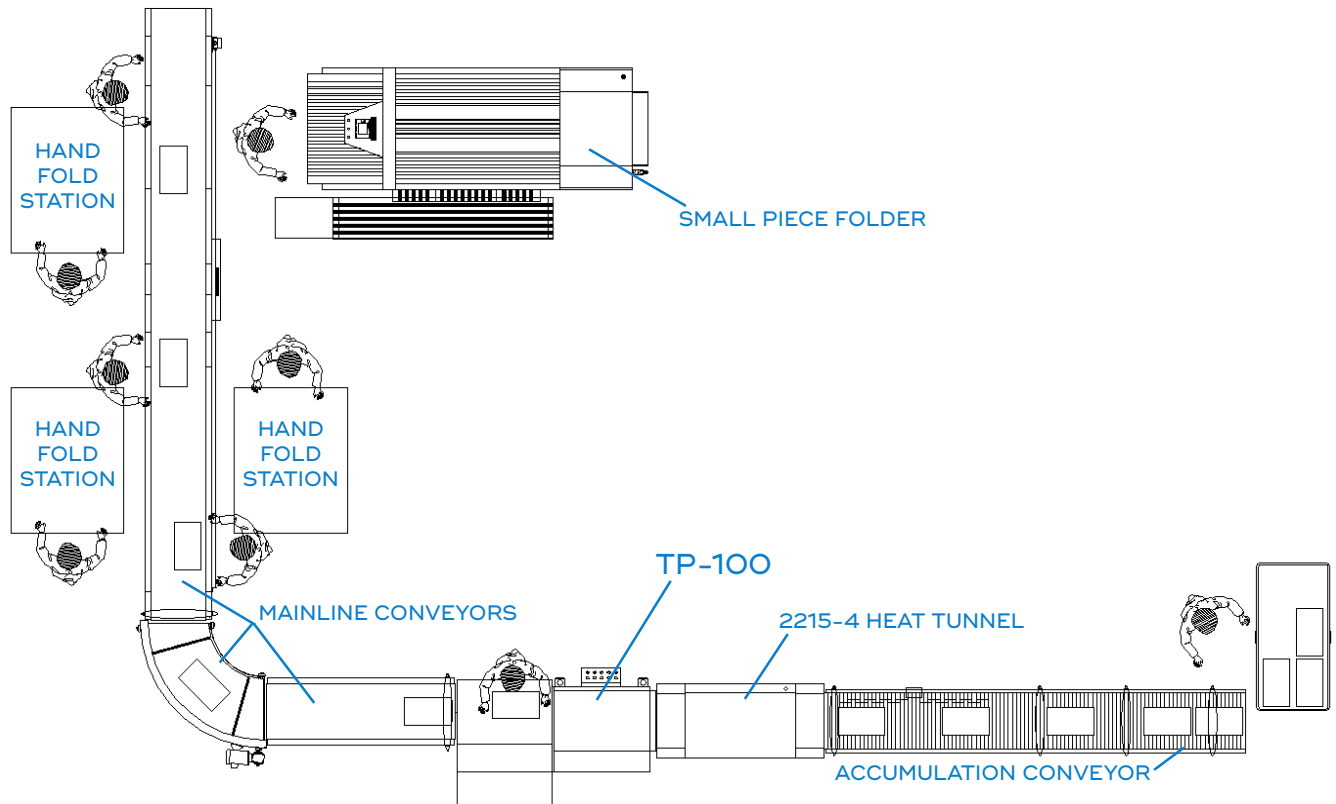



AUTOMATION SYSTEMS

TPS

Small but mighty. That's how we describe the TPS.

Designed to fit in nearly any facility, the TPS can wrap up to 15 pieces per minute (we dare you to try that manually!).

Not only does that mean you can increase throughput, it also means you can reduce the amount of waste generated and number of burns and repetitive motion injuries associated with manual wrapping.



MODEL:	TPS Wrapper	1609-3 Heat Tunnel
MACHINE DIMENSIONS:	39"W x 62"H x 70"L	26"W x 51"H x 47"L
MAX. BUNDLE SIZE:	13.75"W x 4.75"H x 17.75"L	
POWER REQUIREMENTS:	220V	
AIR REQUIREMENTS:	90 psi	N/A
SPEED:	Up to 15 pcs/minute	



AUTOMATION SYSTEMS

TPS - SAMPLE WRAPPING SYSTEM LAYOUT

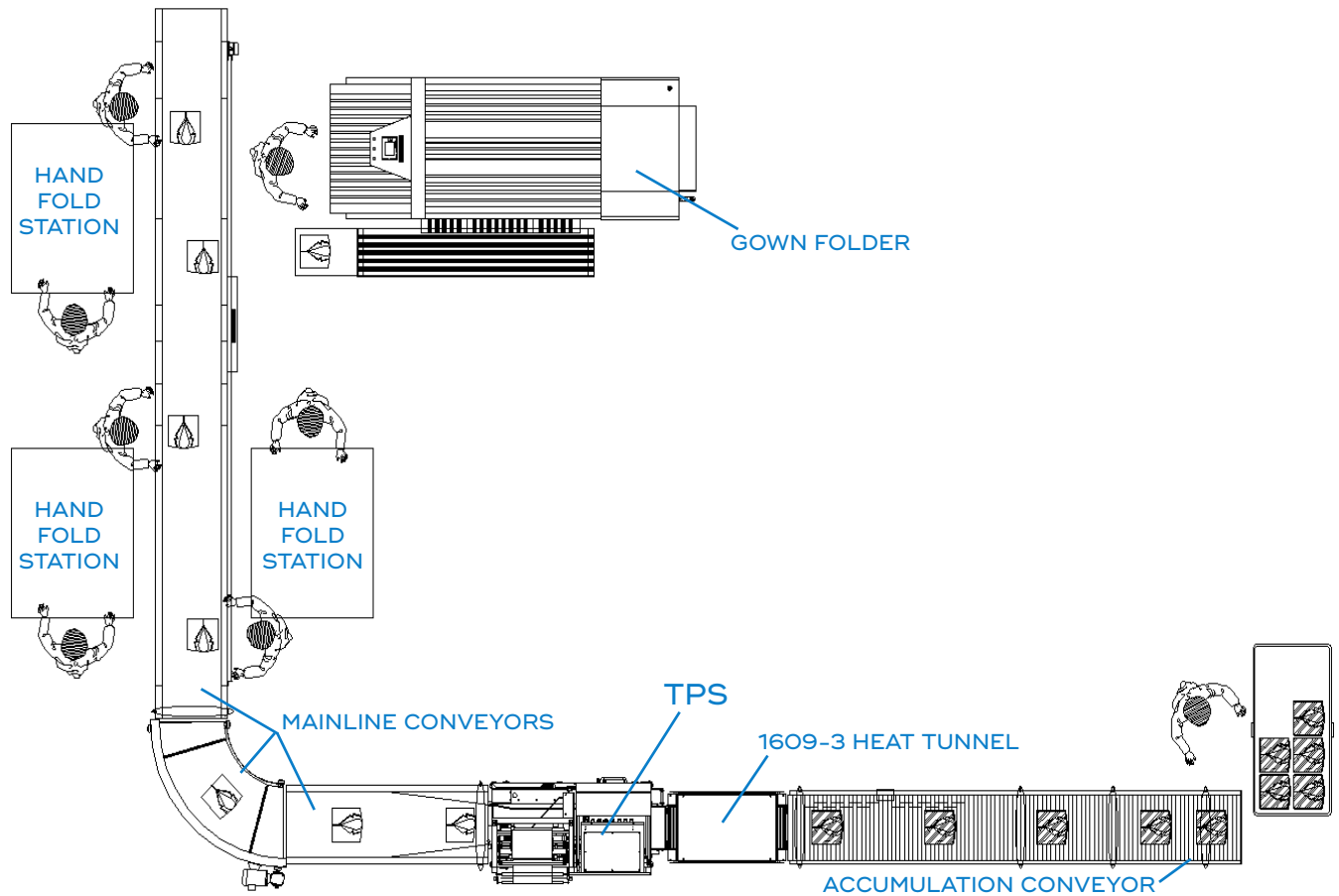



AUTOMATION SYSTEMS

TP-200 & TP-300

The most robust fully automatic laundry bundling systems on the planet, the TP-200 and TP-300 are capable of shrink wrapping bundles of varying size and material while optimizing your productivity and keeping PPOH at an all-time high.

From hand towels and napkins to tablecloths and sheets, our TP-200 & TP-300 systems are the perfect solutions for laundry bundle wrapping.

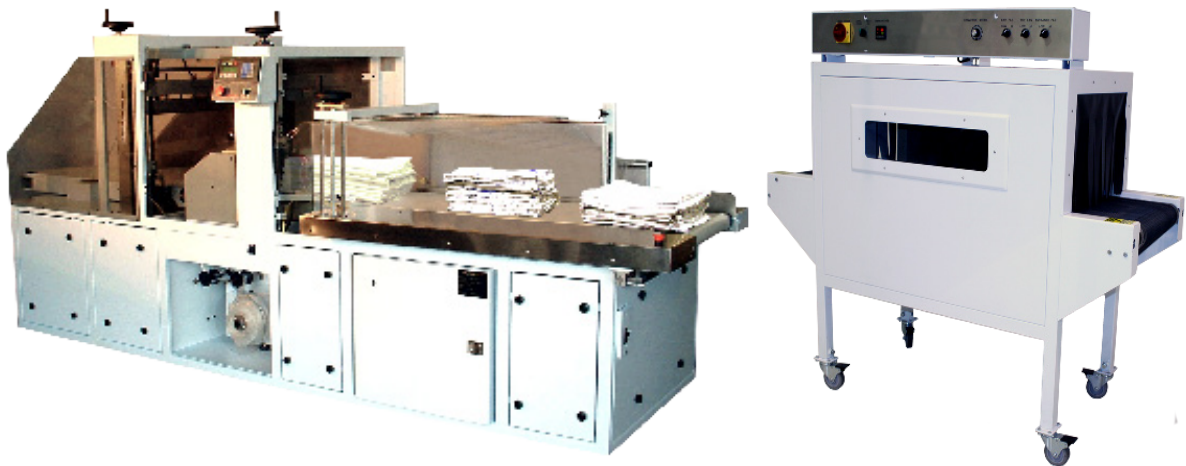

MODEL:	TP-200 Wrapper	TP-300 Wrapper	Heat Tunnels
MACHINE DIMENSIONS:	42"W x 60"H x 106"L	53"W x 70"H x 144"L	Chambers ranging from 2'L to 10'L
MAX. BUNDLE SIZE:	20"W x 7.5"H	20"W x 14"H	See wrapper sizes
POWER REQUIREMENTS:	115V	115V	208V / 230V / 480V
AIR REQUIREMENTS:	90 psi	90 psi	N/A
SPEED:	Up to 15 pcs/minute		



AUTOMATION SYSTEMS

TP-200 & TP-300 - SAMPLE WRAPPING SYSTEM LAYOUT

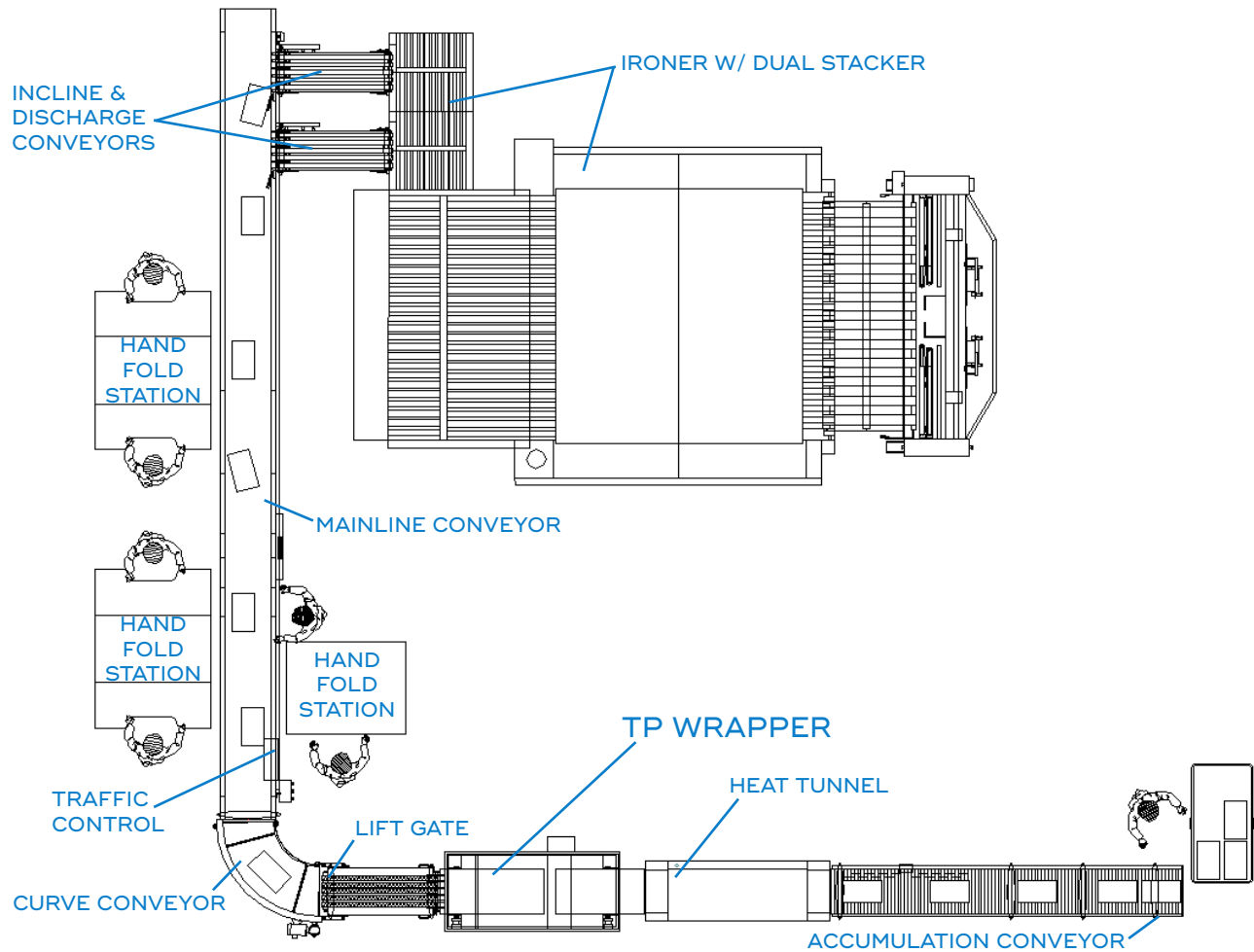

AUTOMATION SYSTEM OPTIONS



Our automated equipment is specifically designed to effectively transport difficult to handle, unstable bundles of laundry. Combined with conveyance, transfer systems and our proprietary Traffic Control Master (TCM), our complete laundry management systems can efficiently move stacks from a folder or stacker through to pack-out without operator assistance.

CONVEYORS

We offer a full line of conveyors build specifically for laundry.

- Belted curve conveyors
- Intelligent accumulation conveyors
- Lift gate conveyors for operator movement
- Incline conveyors
- Mainline conveyors

TRANSFER SYSTEMS

We can direct your bundles! We use a variety of solutions to divert bundles to the proper area of your facility:

- Diverters
- Production identification units
- Corner pushers
- RFID integration

TRAFFIC CONTROL MASTER (TCM)

Anyone can put stock conveyors into your facility but only Felins can integrate everything into a complete transport system and regulate it with our TCM.

Designed for continuous workflow, the TCM manages all bundles from any type of discharge and stacker. By automatically merging bundles from the discharge unit onto the main line conveyor, the TCM maintains appropriate bundle spacing, orientation and stability to prevent crashing and rework.



W204 N13055 Goldendale Rd, Suite 400
Richfield, WI 53076
800-843-5667 . FELINS.COM

